

**NOT RECOMMENDED FOR NEW DESIGNS  
RECOMMENDED REPLACEMENT PART  
ISL98603**

### 4-Channel Integrated LCD Supply

The ISL97650B represents a high power, integrated LCD supply IC targeted at large panel LCD displays. The ISL97650B integrates a high power, 3.2A boost converter for  $V_{DD}$  generation, an integrated  $V_{ON}$  charge pump, a  $V_{OFF}$  charge pump driver,  $V_{ON}$  slicing circuitry and a buck regulator with 2A switch for logic generation.

The ISL97650B has been designed for ease of layout and low BOM cost. Supply sequencing is integrated for both  $V_{DD} \rightarrow V_{OFF} \rightarrow V_{ON}$  and  $V_{DD}/V_{OFF} \rightarrow V_{ON}$  sequences. The TFT power sequence uses a separate enable to the logic buck regulator for maximum flexibility.

Peak efficiencies are >90% for both the boost and buck while operating from a 4.2V to 14V input supply. The current mode buck offers superior line and load regulation. Available in the 36 Ld TQFN package, the ISL97650B is specified for ambient operation over the -40°C to +105°C temperature range.

### Pinout

ISL97650B  
(36 LD TQFN)  
TOP VIEW

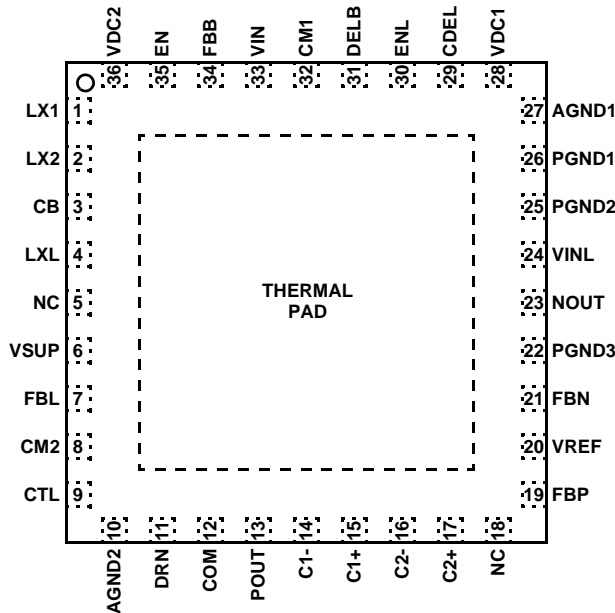

### Features

- 4.2V to 14V Input Supply
- $V_{DD}$  Boost up to 20V, With Integrated 3.2A FET
- Integrated  $V_{ON}$  Charge Pump, Up to 35 $V_{OUT}$
- $V_{OFF}$  Charge Pump Driver, Down to -18V
- $V_{LOGIC}$  Buck Down to 1.2V, With Integrated 2A FET
- Automatic Start-up Sequencing
  - $V_{DD} \rightarrow V_{OFF} \rightarrow V_{ON}$  or  $V_{DD}/V_{OFF} \rightarrow V_{ON}$
  - Independent Logic Enable
- $V_{ON}$  Slicing
- Thermally Enhanced 6x6 Thin QFN Package
- Pb-Free (RoHS compliant)

### Applications

- LCD Monitors (15"+)
- LCD-TVs (up to 40")
- Notebook Displays (up to 16")
- Industrial/Medical LCD Displays

### Ordering Information

PART NUMBER (Note)	PART MARKING	PACKAGE Tape & Reel (Pb-Free)	PKG. DWG. #
ISL97650BIRTZ-T*	ISL976 50BIRTZ	36 Ld 6x6 TQFN	L36.6x6
ISL97650BIRTZ-TK*	ISL976 50BIRTZ	36 Ld 6x6 TQFN	L36.6x6

\*Please refer to TB347 for details on reel specifications.  
NOTE: These Intersil Pb-free plastic packaged products employ special Pb-free material sets, molding compounds/die attach materials, and 100% matte tin plate plus anneal (e3 termination finish, which is RoHS compliant and compatible with both SnPb and Pb-free soldering operations). Intersil Pb-free products are MSL classified at Pb-free peak reflow temperatures that meet or exceed the Pb-free requirements of IPC/JEDEC J STD-020.

**Absolute Maximum Ratings** (T<sub>A</sub> = +25°C)

Maximum Pin Voltages, all pins except below	6.5V
LX1, LX2, VSUP, NOUT, DELB, C2-	.24V
C1-	.14V
VIN1, VINL	16.5V
DRN, COM, POUT, C1+, C2+	.36V
CB	.21V

**Recommended Operating Conditions**

Input Voltage Range, VIN 4.2V to 14V  
 Boost Output Voltage Range, AVDD +20V  
 VON Output Range, VON +15V to +32V  
 VOFF Output Range, VOFF -15V to -5V  
 Logic Output Voltage Range, VLOGIC+1.5V to +3.3V  
 Input Capacitance, CIN2x10µF  
 Boost Inductor, L1 3.3µH to 10µH  
 Output Capacitance, COUT2x22µF  
 Buck Inductor, L23.3µH to 10µH  
 Operating Ambient Temperature Range -40°C to +105°C  
 Operating Junction Temperature -40°C to +125°C

**Thermal Information**

Thermal Resistance	θ <sub>JA</sub> (°C/W)	θ <sub>JC</sub> (°C/W)
6x6 TQFN Package (Notes 1, 2)	30	2.5
Maximum Junction Temperature (Plastic Package)	+150°C	
Maximum Storage Temperature Range	-65°C to +150°C	
Power Dissipation		
T <sub>A</sub> ≤ +25°C	3.3W	
T <sub>A</sub> = +70°C	1.8W	
T <sub>A</sub> = +85°C	1.3W	
T <sub>A</sub> = +100°C	0.8W	
Pb-Free Reflow Profile	see link below	
	<a href="http://www.intersil.com/pbfree/Pb-FreeReflow.asp">http://www.intersil.com/pbfree/Pb-FreeReflow.asp</a>	

*CAUTION: Do not operate at or near the maximum ratings listed for extended periods of time. Exposure to such conditions may adversely impact product reliability and result in failures not covered by warranty.*

**NOTES:**

1. θ<sub>JA</sub> is measured in free air with the component mounted on a high effective thermal conductivity test board with “direct attach” features. See Tech Brief TB379.
2. For θ<sub>JC</sub>, the “case temp” location is the center of the exposed metal pad on the package underside

**Electrical Specifications** V<sub>IN</sub> = 12V, V<sub>BOOST</sub> = V<sub>SUP</sub> = 15V, V<sub>ON</sub> = 25V, V<sub>OFF</sub> = -8V, over temperature from -40°C to +105°C; Parameters with MIN and/or MAX limits are 100% tested at +25°C, unless otherwise specified. Temperature limits established by characterization and are not production tested.

PARAMETER	DESCRIPTION	CONDITIONS	MIN	TYP	MAX	UNIT
<b>SUPPLY PINS</b>						
V <sub>IN</sub>	Supply Voltage (VIN1)		4.2	12	14	V
V <sub>INL</sub>	Logic Supply Voltage		4.2	12	14	V
V <sub>SUP</sub>	Charge Pumps and V <sub>ON</sub> Slice Positive Supply		4.0		20	V
I <sub>VIN</sub>	Quiescent Current into V <sub>IN</sub>	Enabled, No switching		3	5	mA
		Disabled		25	50	µA
I <sub>INL</sub>	Logic Supply Current	Enabled, No switching		0.25	2	mA
		Disabled		1	25	µA
I <sub>SUP</sub>	V <sub>SUP</sub> Supply Current	Enabled, No Switching and V <sub>POUT</sub> = V <sub>SUP</sub>			1	mA
		Disabled		1	10	µA
VLOR	Undervoltage Lockout Threshold	V <sub>DC</sub> rising		3.85	4.0	V
VLOF	Undervoltage Lockout Threshold	V <sub>DC</sub> falling	3.3	3.8		V
V <sub>REF</sub>	Reference Voltage	T <sub>A</sub> = +25°C	1.18	1.205	1.225	V
			1.177	1.205	1.228	V
F <sub>OSC</sub>	Oscillator Frequency		440	500	560	kHz
<b>AVDD BOOST</b>						
D <sub>MIN</sub>	Minimum Duty Cycle			7	10	%
D <sub>MAX</sub>	Maximum Duty Cycle		92	94	96	%

## ISL97650B

**Electrical Specifications**  $V_{IN} = 12V$ ,  $V_{BOOST} = V_{SUP} = 15V$ ,  $V_{ON} = 25V$ ,  $V_{OFF} = -8V$ , over temperature from  $-40^{\circ}C$  to  $+105^{\circ}C$ ; Parameters with MIN and/or MAX limits are 100% tested at  $+25^{\circ}C$ , unless otherwise specified. Temperature limits established by characterization and are not production tested. **(Continued)**

PARAMETER	DESCRIPTION	CONDITIONS	MIN	TYP	MAX	UNIT
ILX	LX Leakage Current	LX = 0V and 24V	-50	0.1	50	$\mu A$
$V_{BOOST}$	Boost Output Range		$1.25 * V_{IN}$		20	V
$I_{BOOST}$	Boost Switch Current	Current limit	2.6	3.2	3.85	A
$EFF_{BOOST}$	Peak Efficiency	See graphs and component recommendations		90+		%
$r_{DS(ON)}$	Switch ON-Resistance			160	300	m $\Omega$
$\Delta V_{BOOST}/\Delta V_{IN}$	Line Regulation	$5V < V_{IN} < 13V$ , load = 300mA		0.08	0.4	%/V
$\Delta V_{BOOST}/\Delta I_{OUT}$	Load Regulation	$100mA < I_{load} < 200mA$		0.1	0.5	%
$V_{FBB}$	Boost Feedback Voltage	$T_A = +25^{\circ}C$	1.192	1.205	1.218	V
			1.188	1.205	1.222	V
$ACC_{BOOST}$	$A_{VDD}$ Output Accuracy	$T_A = +25^{\circ}C$	-1.5		1.5	%
$t_{SS}$	Soft-Start Period for $A_{VDD}$	$C_{DEL} = 220nF$		9.6		ms
<b>V<sub>LOGIC</sub> BUCK</b>						
$V_{BUCK}$	Buck Output Voltage	Output current = 0.5A	1.5		5.5	V
$I_{BUCK}$	Buck Switch Current	Current limit	2.0	2.4	2.9	A
$EFF_{BUCK}$	Peak Efficiency	See graphs and component recommendations		92		%
$r_{DS-ONBK}$	Switch ON-Resistance			200	400	m $\Omega$
$\Delta V_{BUCK}/\Delta V_{IN}$	Line Regulation	$5V < V_{IN} < 13V$ , load = 300mA		0.01	0.15	%/V
$\Delta V_{BUCK}/\Delta I_{OUT}$	Load Regulation	$100mA < I_{load} < 500mA$		0.2	1	%
$V_{FBL}$	FBL Regulation Voltage	$T_A = +25^{\circ}C$	1.176	1.2	1.224	V
			1.174	1.2	1.226	V
$ACC_{LOGIC}$	$V_{LOGIC}$ Output Accuracy	$T_A = +25^{\circ}C$	-2		2	%
$D_{MIN}$ BUCK	Minimum Duty Cycle			10	16	%
$D_{MAX}$ BUCK	Maximum Duty Cycle		91	92	94	%
$t_{ssL}$	Soft-Start Period for $V_{LOGIC}$	$C(V_{REF}) = 220nF$ (Note - no soft-start if EN asserted HIGH before ENB)		0.5		ms
<b>NEGATIVE (<math>V_{OFF}</math>) CHARGE PUMP</b>						
$V_{OFF}$	$V_{OFF}$ Output Voltage Range	2x Charge Pump	$-V_{SUP} + 1.4V$		0	V
$I_{Load\_NCP\_min}$	External Load Driving Capability	$V_{SUP} > 5V$	30			mA
$R_{ON(NOUT)H}$	High-Side Driver ON-Resistance at $N_{OUT}$	$I(N_{OUT}) = +60mA$			10	$\Omega$
$R_{ON(NOUT)L}$	Low-Side Driver ON-Resistance at $N_{OUT}$	$I(N_{OUT}) = -60mA$			5	$\Omega$
$I_{pu(NOUT)lim}$	Pull-Up Current Limit in $N_{OUT}$	$V(N_{OUT}) = 0V$ to $V(SUP) - 0.5V$	60	270		mA
$I_{pd(NOUT)lim}$	Pull-Down Current Limit in $N_{OUT}$	$V(N_{OUT}) = 0.36V$ to $V(SUP)$		-200	-60	mA
$I(N_{OUT})_{leak}$	Leakage Current in $N_{OUT}$	$V(FBN) < 0$ or $EN = LOW$	-5		5	$\mu A$
$V_{FBN}$	FBN Regulation Voltage	$T_A = +25^{\circ}C$	0.173	0.203	0.233	V
			0.171	0.203	0.235	V
$ACCN$	$V_{OFF}$ Output Accuracy	$I_{OFF} = 1mA$ , $T_A = +25^{\circ}C$	-3		+3	%

## ISL97650B

**Electrical Specifications**  $V_{IN} = 12V$ ,  $V_{BOOST} = V_{SUP} = 15V$ ,  $V_{ON} = 25V$ ,  $V_{OFF} = -8V$ , over temperature from  $-40^{\circ}C$  to  $+105^{\circ}C$ ; Parameters with MIN and/or MAX limits are 100% tested at  $+25^{\circ}C$ , unless otherwise specified. Temperature limits established by characterization and are not production tested. **(Continued)**

PARAMETER	DESCRIPTION	CONDITIONS	MIN	TYP	MAX	UNIT
D_NCP_max	Max Duty Cycle of the Negative Charge Pump			50		%
Rpd(FBN)off	Pull-Down Resistance, Not Active	I(FBN) = 500 $\mu$ A	1.5	3.3	5.5	k $\Omega$
<b>POSITIVE (V<sub>ON</sub>) CHARGE PUMP</b>						
V <sub>ON</sub>	V <sub>ON</sub> Output Voltage Range	2x or 3x Charge Pump		V <sub>SUP</sub> +2V	34	V
I <sub>Load_PCP_min</sub>	External Load Driving Capability	V <sub>ON</sub> = 25V (2x Charge Pump)	20			mA
		V <sub>ON</sub> = 34V (3x Charge Pump)	20			mA
R <sub>ON(VSUP_SW)</sub>	ON-Resistance of V <sub>SUP</sub> Input Switch	I(switch) = +40mA		10	17	$\Omega$
R <sub>ON(C1/2-)H</sub>	High-Side Driver ON-Resistance at C1- and C2-	I(C1/2-) = +40mA			30	$\Omega$
R <sub>ON(C1/2-)L</sub>	Low-Side Driver ON-Resistance at C1- and C2-	I(C1/2-) = -40mA		4	7	$\Omega$
I <sub>pu(VSUP_SW)</sub>	Pull-Up Current Limit in V <sub>SUP</sub> Input Switch	V(C2+) = 0V to V(SUP) - 0.4V - V(diode)	40	100		mA
I <sub>pu(C1/2-)</sub>	Pull-Up Current Limit in C1- and C2-	V(C1/2-) = 0V to V(VSUP) - 0.4V	40	100		mA
I <sub>pd(C1/2-)</sub>	Pull-Down Current Limit in C1- and C2-	V(C1/2-) = 0.2V to V(VSUP)		-100	-40	mA
I(POUT)leak	Leakage Current in P <sub>OUT</sub>	EN = LOW	-5		5	$\mu$ A
V <sub>FBP</sub>	FBP Regulation Voltage	T <sub>A</sub> = +25 $^{\circ}C$	1.176	1.2	1.224	V
			1.172	1.2	1.228	V
ACCP	V <sub>ON</sub> Output Accuracy	I <sub>ON</sub> = 1mA, T <sub>A</sub> = +25 $^{\circ}C$	-2		+2	%
D_PCP_max	Max Duty Cycle of the Positive Charge Pump			50		%
V(diode)	Internal Schottky Diode Forward Voltage	I(diode) = +40mA		700	800	mV
<b>ENABLE INPUTS</b>						
VHI-EN	Enable "HIGH"		2.2			V
VLO-EN	Enable "LOW"				0.8	V
IEN_pd	Enable Pin Pull-Down Current	V <sub>EN</sub> > VLO-EN			25	$\mu$ A
VHI-ENL	Logic Enable "HIGH"		2.2			V
VLO-ENL	Logic Enable "LOW"				0.8	V
IENL_pd	Logic Enable Pin Pull-Down Current	V <sub>ENL</sub> > VLO-ENL			25	$\mu$ A
<b>V<sub>ON</sub> SLICE POSITIVE SUPPLY = V(POUT)</b>						
I(POUT)_slice	V <sub>ON</sub> Slice Current from P <sub>OUT</sub> Supply	CTL = VDD, sequence complete		200	400	$\mu$ A
		CTL = AGND, sequence complete		100	150	$\mu$ A
R <sub>ON(POUT-COM)</sub>	ON-Resistance between P <sub>OUT</sub> - COM	CTL = VDD, sequence complete		5	10	$\Omega$
R <sub>ON(DRN-COM)</sub>	ON-Resistance between DRN - COM	CTL = ACGND, sequence complete		30	60	$\Omega$
R <sub>ON_COM</sub>	ON-Resistance between COM and PGND3		200	500	1500	$\Omega$
VLO	CTL Input LOW Voltage				0.8	V
VHI	CTL Input HIGH Voltage		2.2			V

# ISL97650B

**Electrical Specifications**  $V_{IN} = 12V$ ,  $V_{BOOST} = V_{SUP} = 15V$ ,  $V_{ON} = 25V$ ,  $V_{OFF} = -8V$ , over temperature from  $-40^{\circ}C$  to  $+105^{\circ}C$ ; Parameters with MIN and/or MAX limits are 100% tested at  $+25^{\circ}C$ , unless otherwise specified. Temperature limits established by characterization and are not production tested. **(Continued)**

PARAMETER	DESCRIPTION	CONDITIONS	MIN	TYP	MAX	UNIT
<b>FAULT DETECTION THRESHOLDS</b>						
T_off	Thermal Shut-Down (latched and reset by power cycle or EN cycle)	Temperature rising		150		$^{\circ}C$
Vth_AVDD(FBB)	AVDD Boost Short Detection	V(FBB) falling less than		0.9		V
Vth_VLOGIC(FBL)	VLOGIC Buck Short Detection	V(FBL) falling less than		0.9		V
Vth_POOUT(FBP)	POUT Charge Pump Short Detection	V(FBP) falling less than		0.9		V
Vth_NOOUT(FBN)	NOOUT Charge Pump Short Detection	V(FBN) rising more than		0.4		V
tFD	Fault Delay Time to Chip Turns Off			52		ms
<b>START-UP SEQUENCING</b>						
tSTART-UP	Enable to AVDD Start Time	$C_{DEL} = 220nF$		80		ms
IDELB_ON	DELB Pull-Down Current or Resistance when Enabled by the Start-Up Sequence	$V_{DELB} > 0.9V$	36	50	70	$\mu A$
		$V_{DELB} < 0.9V$	1.00	1.326	1.75	$k\Omega$
IDELB_OFF	DELB Pull-Down Current or Resistance when Disabled	$V_{DELB} < 20V$			500	nA
CDEL	Sequence Timing and Fault Time Out Capacitor		10		220	nF
tVOFF	AVDD to VOFF	$C_{DEL} = 220nF$		9		ms
tVON	VOFF to VON Delay	$C_{DEL} = 220nF$		20		ms
tVON-SLICE	VON to VON-SLICE Delay	$C_{DEL} = 220nF$		17		ms

## Typical Performance Curves

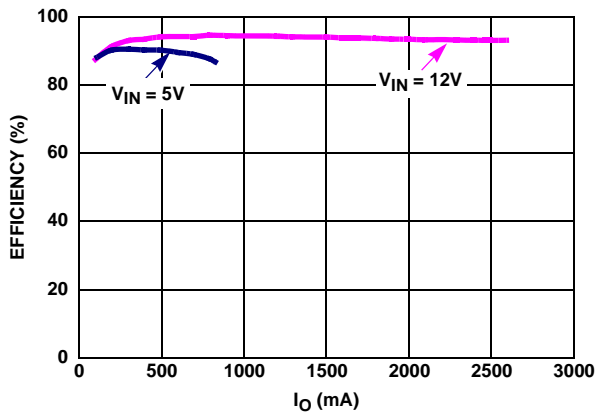

FIGURE 1. BOOST EFFICIENCY

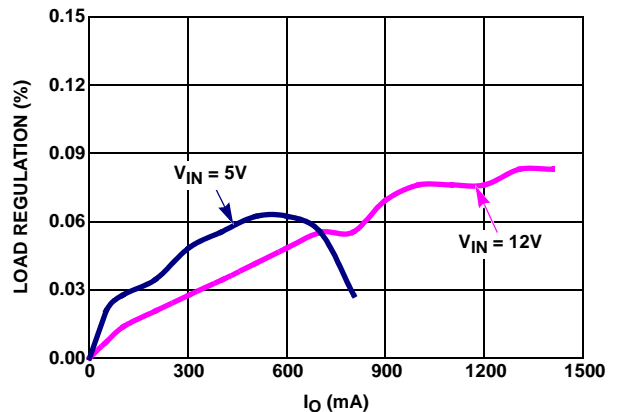

FIGURE 2. BOOST LOAD REGULATION

Typical Performance Curves (Continued)

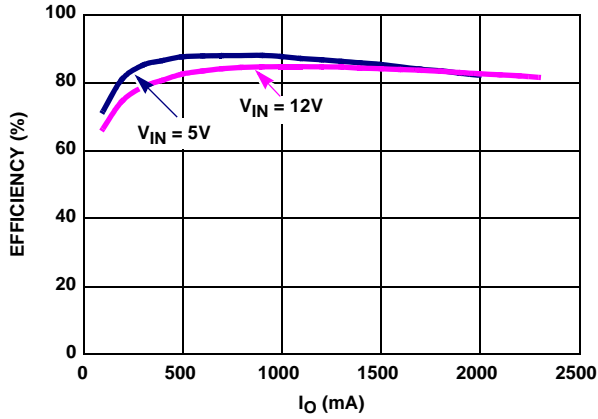

FIGURE 3. BUCK EFFICIENCY

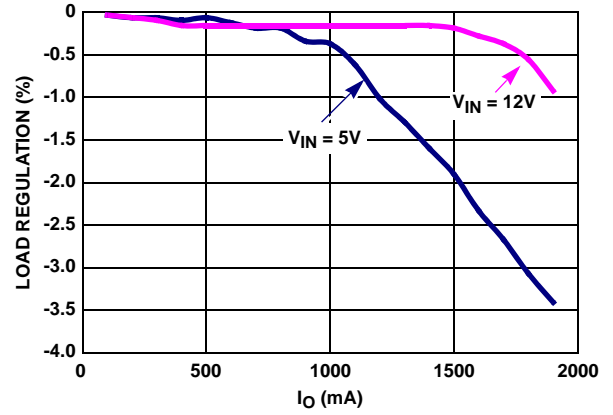

FIGURE 4. BUCK LOAD REGULATION

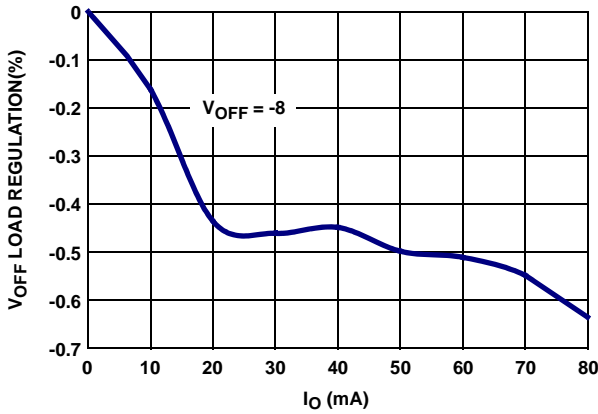

FIGURE 5. V<sub>OFF</sub> LOAD REGULATION vs I<sub>OFF</sub>

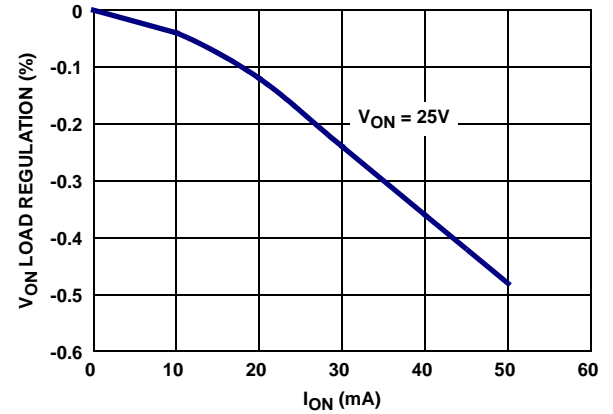

FIGURE 6. V<sub>ON</sub> LOAD REGULATION vs I<sub>ON</sub>

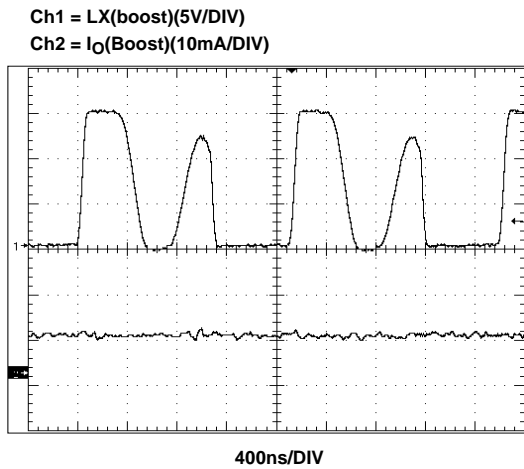

FIGURE 7. BOOST DISCONTINUOUS MODE

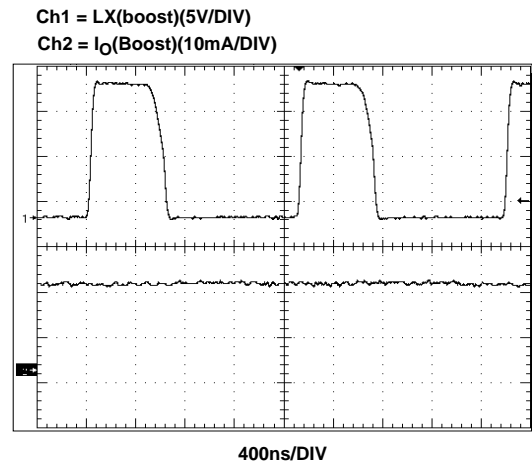

FIGURE 8. THRESHOLD OF BOOST FROM DC TO CC MODE

Typical Performance Curves (Continued)

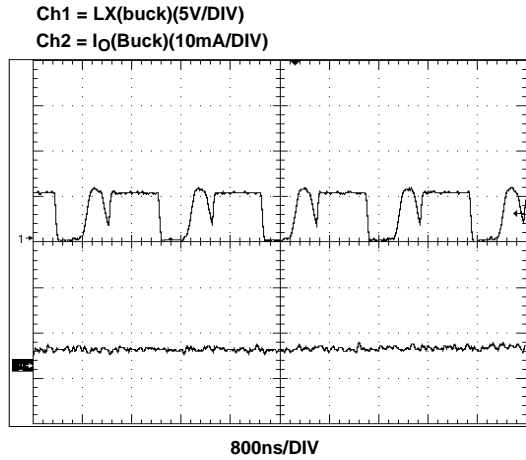

FIGURE 9. BUCK DISCONTINUOUS MODE

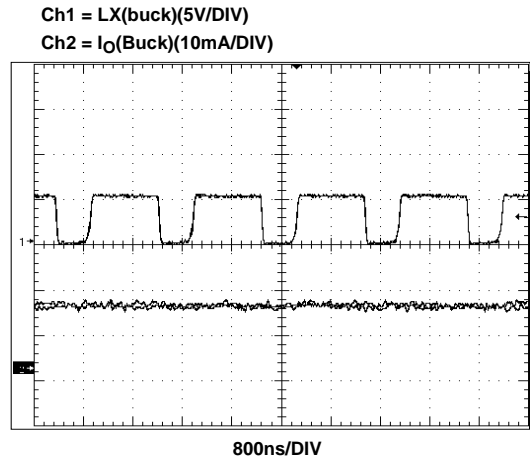

FIGURE 10. THRESHOLD OF BUCK FROM DC TO CC MODE

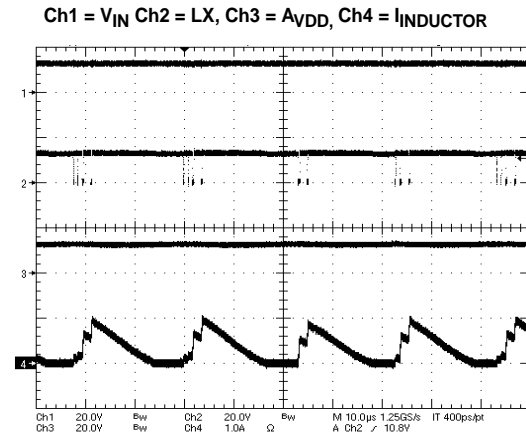

FIGURE 11. BOOST CONVERTER PULSE-SKIPPING MODE WAVEFORM

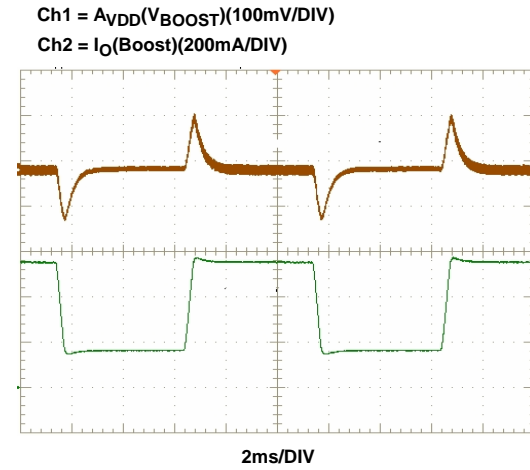

FIGURE 12. TRANSIENT RESPONSE OF BOOST

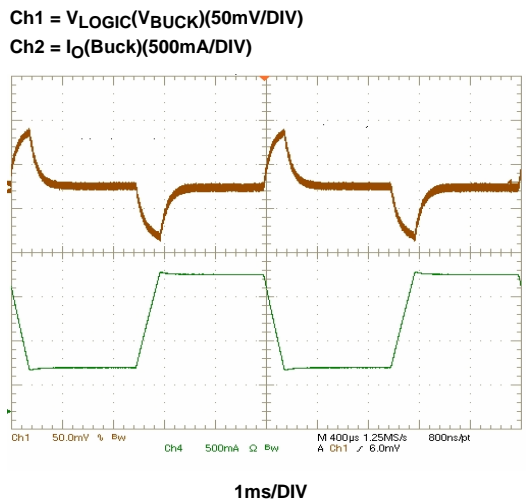

FIGURE 13. TRANSIENT RESPONSE OF BUCK

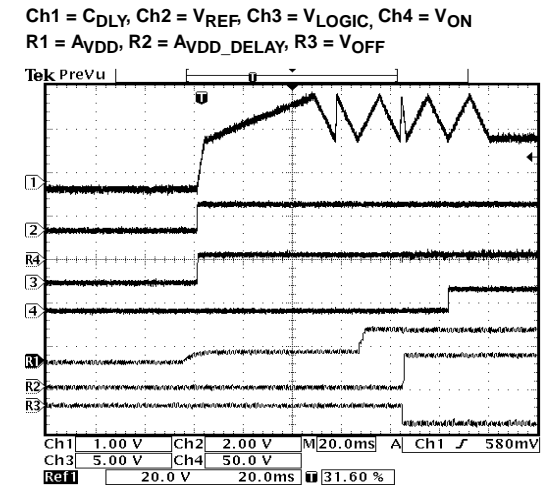

FIGURE 14. START-UP SEQUENCE

**Pin Descriptions**

PIN NUMBER	PIN NAME	DESCRIPTION
1	LX1	Internal boost switch connection
2	LX2	Internal boost switch connection
3	CB	Logic buck, boost strap pin
4	LXL	Buck converter output
5, 18	NC	No connect. Connect to die pad and GND for improved thermal efficiency.
6	VSUP	Positive supply for charge pumps
7	FBL	Logic buck feedback pin
8	CM2	Buck compensation network pin
9	CTL	Input control for $V_{ON}$ slice output
10	AGND2	Signal GND pin
11	DRN	Lower reference voltage for $V_{ON}$ slice output
12	COM	$V_{ON}$ slice output: when CTL = 1, COM is connected to SRC through a 5 $\Omega$ resistor; when CTL = 0, COM is connected to DRN through a 30 $\Omega$ resistor
13	POUT	Positive charge pump out
14	C1-	Charge pump capacitor 1, negative connection
15	C1+	Charge pump capacitor 1, positive connection
16	C2-	Charge pump capacitor 2, negative connection
17	C2+	Charge pump capacitor 2, positive connection
19	FBP	Positive charge pump feedback pin
20	VREF	Reference voltage
21	FBN	Negative charge pump feedback pin
22	PGND3	Power ground for $V_{OFF}$ , $V_{ON}$ and $V_{ON}$ slice
23	NOUT	Negative charge pump output
24	VINL	Logic buck supply voltage
25, 26	PGND2, PGND1	Boost Power grounds
27	AGND1	Signal ground pin
28	VDC1	Internal supply decoupling capacitor
29	CDEL	Delay capacitor for start up sequencing, soft-start and fault detection timers
30	ENL	Buck enable for $V_{LOGIC}$ output
31	DELB	Open drain NFET output to drive optional $A_{VDD}$ delay PFET
32	CM1	Boost compensation network pin
33	VIN	Input voltage pin
34	FBB	Boost feedback pin
35	EN	Enable for Boost, charge pumps and $V_{ON}$ slice (independent of ENL)
36	VDC2	Internal supply decoupling capacitor
Thermal Pad	N/A	Connect exposed die plate on rear of package to ACGND and the PGND1, 2 pins. See "Layout Recommendation" on page 19 for PCB layout thermal considerations.



Block Diagram

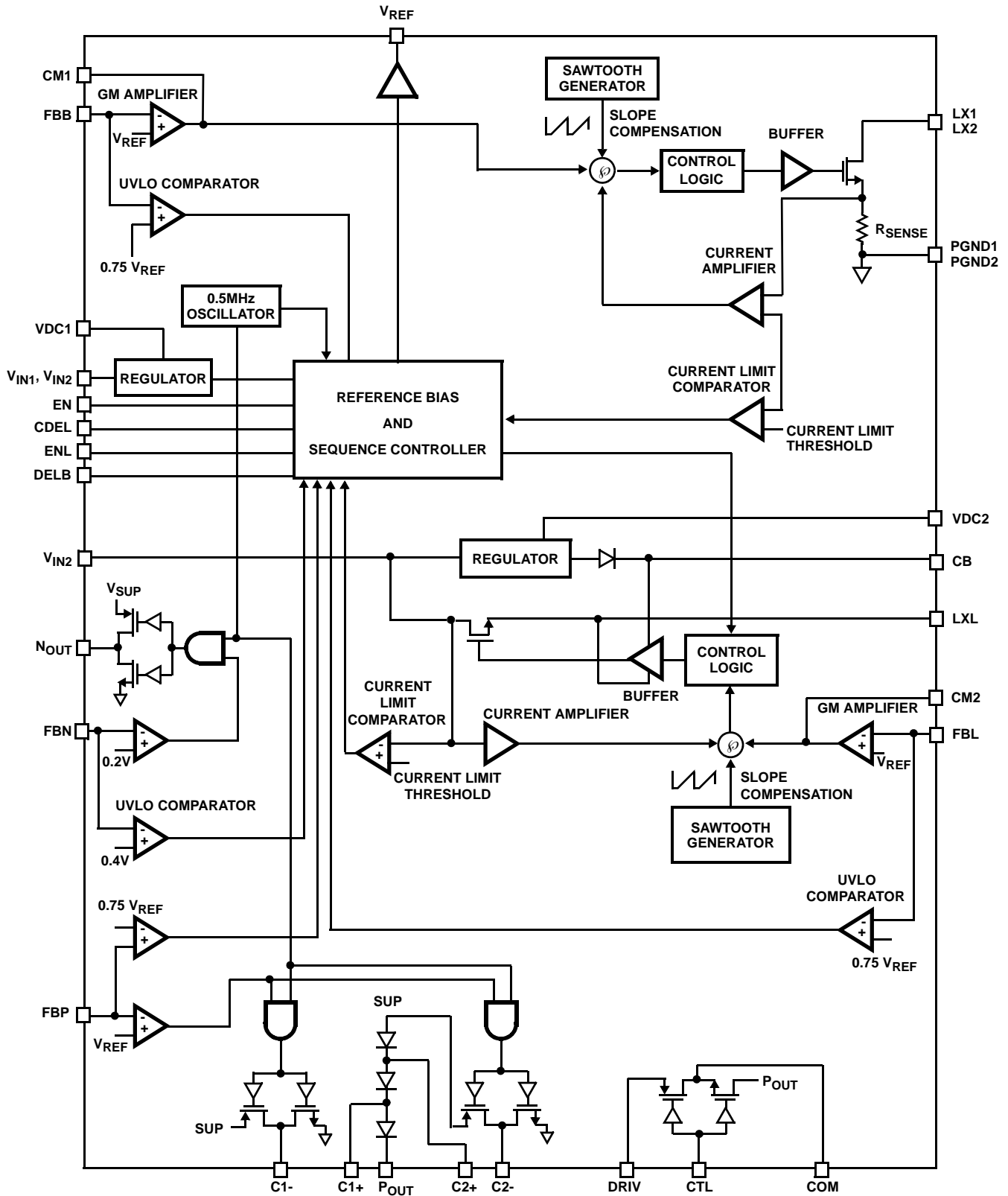

Typical Application Diagram

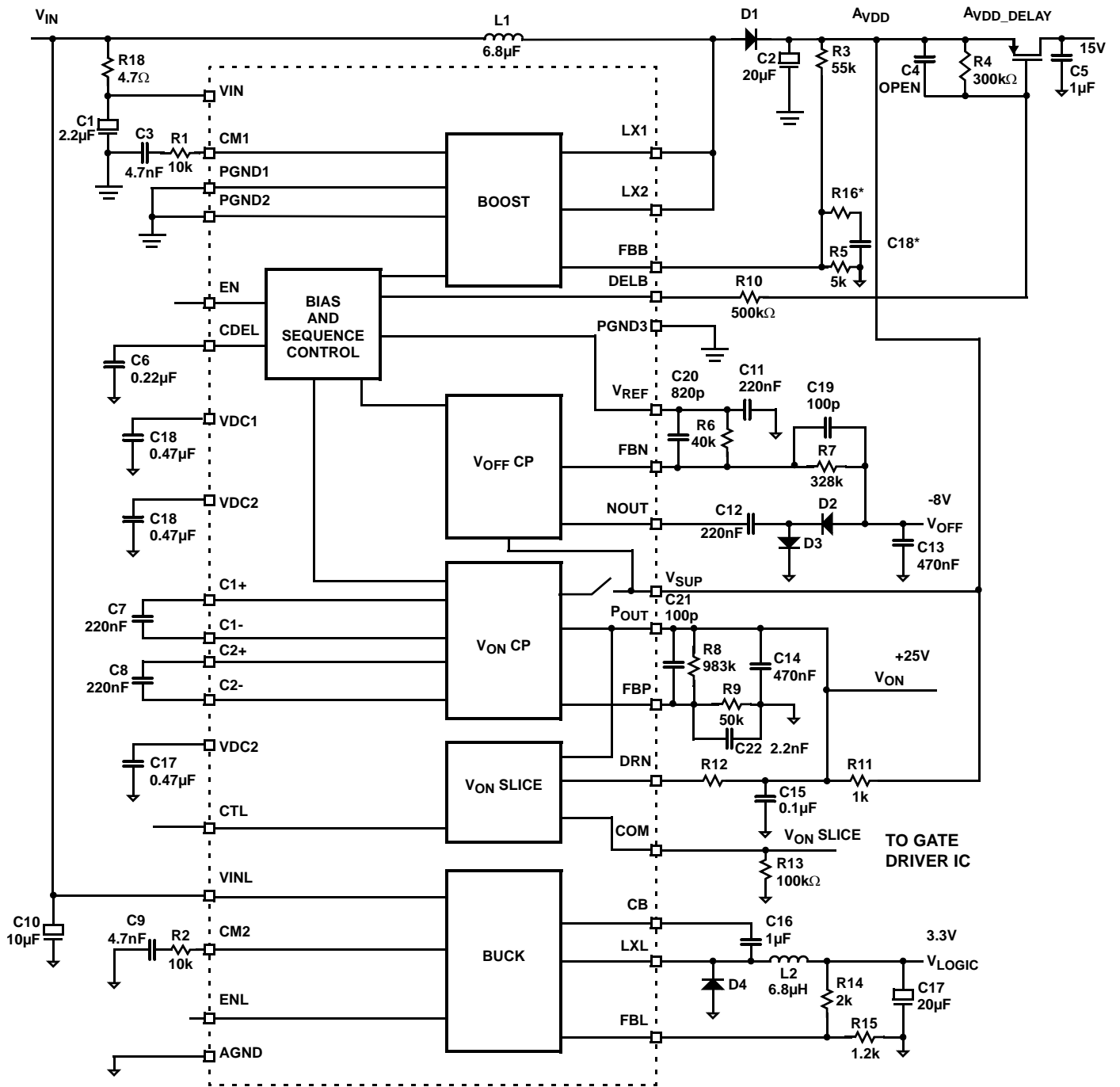

\*Open Component Positions

## Applications Information

The ISL97650B provides a complete power solution for TFT LCD applications. The system consists of one boost converter to generate  $A_{VDD}$  voltage for column drivers, one buck converter to provide voltage to logic circuit in the LCD panel, one integrated  $V_{ON}$  charge pump and one  $V_{OFF}$  linear-regulator controller to provide the voltage to row drivers. This part also integrates  $V_{ON}$ -slice circuit which can help to optimize the picture quality. With the high output current capability, this part is ideal for big screen LCD TV and monitor panel application.

The integrated boost converter and buck converter operate at 0.5MHz which can allow to use multilayer ceramic capacitors and low profile inductor which result in low cost, compact and reliable system. The logic output voltage is independently enabled to give flexibility to the system designers.

### Boost Converter

The boost converter is a current mode PWM converter operating at a fixed frequency of 0.5MHz. It can operate in both discontinuous conduction mode (DCM) at light load and continuous mode (CCM). In continuous current mode, current flows continuously in the inductor during the entire switching cycle in steady state operation. The voltage conversion ratio in continuous current mode is given by Equation 1:

$$\frac{V_{boost}}{V_{IN}} = \frac{1}{1-D} \quad (\text{EQ. 1})$$

Where D is the duty cycle of the switching MOSFET.

The boost converter uses a summing amplifier architecture consisting of gm stages for voltage feedback, current feedback and slope compensation. A comparator looks at the peak inductor current cycle by cycle and terminates the PWM cycle if the current limit is reached.

An external resistor divider is required to divide the output voltage down to the nominal reference voltage. Current drawn by the resistor network should be limited to maintain the overall converter efficiency. The maximum value of the resistor network is limited by the feedback input bias current and the potential for noise being coupled into the feedback pin. A resistor network in the order of 60k $\Omega$  is recommended. The boost converter output voltage is determined by Equation 2:

$$A_{VDD} = \frac{R3+R5}{R5} \times V_{FBB} \quad (\text{EQ. 2})$$

The current through the MOSFET is limited to 3.2A<sub>peak</sub>. This restricts the maximum output current (average) based on Equation 3:

$$I_{OMAX} = \left( I_{LMT} - \frac{\Delta I_L}{2} \right) \times \frac{V_{IN}}{V_O} \quad (\text{EQ. 3})$$

Where  $\Delta I_L$  is peak to peak inductor ripple current, and is set by Equation 4:

$$\Delta I_L = \frac{V_{IN}}{L} \times \frac{D}{f_s} \quad (\text{EQ. 4})$$

where  $f_s$  is the switching frequency(0.5MHz).

Table 1 gives typical values (margins are considered 10%, 3%, 20%, 10% and 15% on  $V_{IN}$ ,  $V_O$ , L,  $f_s$  and  $I_{OMAX}$ ):

TABLE 1. MAXIMUM OUTPUT CURRENT CALCULATION

$V_{IN}$ (V)	$V_O$ (V)	L ( $\mu$ H)	$f_s$ (MHz)	$I_{OMAX}$ (mA)
5	9	6.8	0.5	1138
5	12	6.8	0.5	777
4	15	6.8	0.5	560
12	15	6.8	0.5	1345
12	18	6.8	0.5	998

The minimum duty cycle of the ISL97650B is 25%. When the operating duty cycle is lower than the minimum duty cycle, the part will not switch in some cycles randomly, which will cause some LX pulses to be skipped. In this case, LX pulses are not consistent any more, but the output voltage ( $A_{VDD}$ ) is still regulated by the ratio of R3 and R5. This relationship is given by Equation 2. Because some LX pulses are skipped, the ripple current in the inductor will become bigger. Under the worst case, the ripple current will be from 0 to the threshold of the current limit. In turn, the bigger ripple current will increase the output voltage ripple. Hence, it will need more output capacitors to keep the output ripple at the same level. When the input voltage equals, or is larger than, the output voltage, the boost converter will stop switching. The boost converter is not regulated any more, but the part will still be on and other channels are still regulated. The typical waveforms of pulse-skipping mode are shown in the "Typical Performance Curves" on page 5.

### Boost Converter Input Capacitor

An input capacitor is used to suppress the voltage ripple injected into the boost converter. The ceramic capacitor with capacitance larger than 10 $\mu$ F is recommended. The voltage rating of input capacitor should be larger than the maximum input voltage. Some capacitors are recommended in Table 2 for input capacitor.

TABLE 2. BOOST CONVERTER INPUT CAPACITOR RECOMMENDATION

CAPACITOR	SIZE	VENDOR	PART NUMBER
10 $\mu$ F/25V	1210	TDK	C3225X7R1E106M
10 $\mu$ F/25V	1210	Murata	GRM32DR61E106K

### Boost Inductor

The boost inductor is a critical part which influences the output voltage ripple, transient response, and efficiency. Values of 3.3μH to 10μH are to match the internal slope compensation. The inductor must be able to handle the following average and peak current:

$$I_{LAVG} = \frac{I_O}{1-D} \quad (\text{EQ. 5})$$

$$I_{LPK} = I_{LAVG} + \frac{\Delta I_L}{2} \quad (\text{EQ. 6})$$

Some inductors are recommended in Table 3.

**TABLE 3. BOOST INDUCTOR RECOMMENDATION**

INDUCTOR	DIMENSIONS (mm)	VENDOR	PART NUMBER
6.8μH/ 3A <sub>PEAK</sub>	7.3x6.8x3.2	TDK	RLF7030T-6R8N3R0
6.8μH/ 2.9A <sub>PEAK</sub>	7.6x7.6x3.0	Sumida	CDR7D28MNNP-6R8NC
5.2μH/ 4.55A <sub>PEAK</sub>	10x10.1x3.8	Cooper Bussmann	CD1-5R2

### Rectifier Diode (Boost Converter)

A high-speed diode is necessary due to the high switching frequency. Schottky diodes are recommended because of their fast recovery time and low forward voltage. The reverse voltage rating of this diode should be higher than the maximum output voltage. The rectifier diode must meet the output current and peak inductor current requirements. Table 4 shows some recommendations for boost converter diode.

**TABLE 4. BOOST CONVERTER RECTIFIER DIODE RECOMMENDATION**

DIODE	V <sub>R</sub> /I <sub>AVG</sub> RATING	PACKAGE	VENDOR
SS23	30V/2A	SMB	Fairchild Semiconductor
SL23	30V/2A	SMB	Vishay Semiconductor

### Output Capacitor

The output capacitor supplies the load directly and reduces the ripple voltage at the output. Output ripple voltage consists of two components: the voltage drop due to the inductor ripple current flowing through the ESR of output capacitor, and the charging and discharging of the output capacitor.

$$V_{RIPPLE} = I_{LPK} \times ESR + \frac{V_O - V_{IN}}{V_O} \times \frac{I_O}{C_{OUT}} \times \frac{1}{f_s} \quad (\text{EQ. 7})$$

For low ESR ceramic capacitors, the output ripple is dominated by the charging and discharging of the output capacitor. The voltage rating of the output capacitor should be greater than the maximum output voltage.

Note: Capacitors have a voltage coefficient that makes their effective capacitance drop as the voltage across them increases. C<sub>OUT</sub> in Equation 7 assumes the effective value of the capacitor at a particular voltage and not the manufacturer's stated value, measured at 0V.

Table 5 shows some selections of output capacitors.

**TABLE 5. BOOST OUTPUT CAPACITOR RECOMMENDATION**

CAPACITOR	SIZE	VENDOR	PART NUMBER
10μF/25V	1210	TDK	C3225X7R1E106M
10μF/25V	1210	Murata	GRM32DR61E106K

### PI Loop Compensation (Boost Converter)

The boost converter of ISL97650B can be compensated by a RC network connected from CM1 pin to ground. C3 = 4.7nF and R1 = 10k RC network is used in the demo board. A higher resistor value can be used to lower the transient overshoot - however, this may be at the expense of stability to the loop.

The stability can be examined by repeatedly changing the load between 100mA and a max level that is likely to be used in the system being used. The A<sub>VDD</sub> voltage should be examined with an oscilloscope set to AC 100mV/div and the amount of ringing observed when the load current changes. Reduce excessive ringing by reducing the value of the resistor in series with the CM1 pin capacitor.

### Boost Converter Feedback Resistors and Capacitor

An RC network across feedback resistor R5 may be required to optimize boost stability when A<sub>VDD</sub> voltage is set to less than 12V. This network reduces the internal voltage feedback used by the IC. This RC network sets a pole in the control loop. This pole is set to approximately f<sub>p</sub> = 10kHz for C<sub>OUT</sub> = 10μF and f<sub>p</sub> = 4kHz for C<sub>OUT</sub> = 30μF. Alternatively, adding a small capacitor (20pF to 100pF) in parallel with R5 (i.e. R16 = short) may help to reduce A<sub>VDD</sub> noise and improve regulation, particularly if high value feedback resistors are used.

$$R16 = \left( \left( \frac{1}{0.1 \times R5} \right) - \frac{1}{R3} \right)^{-1} \quad (\text{EQ. 8})$$

$$C18 = \frac{1}{(2 \times 3.142 \times f_p \times R15)} \quad (\text{EQ. 9})$$

**Cascaded MOSFET Application**

An 20V N-channel MOSFET is integrated in the boost regulator. For the applications where the output voltage is greater than 20V, an external cascaded MOSFET is needed as shown in Figure 15. The voltage rating of the external MOSFET should be greater than  $V_{VDD}$ .

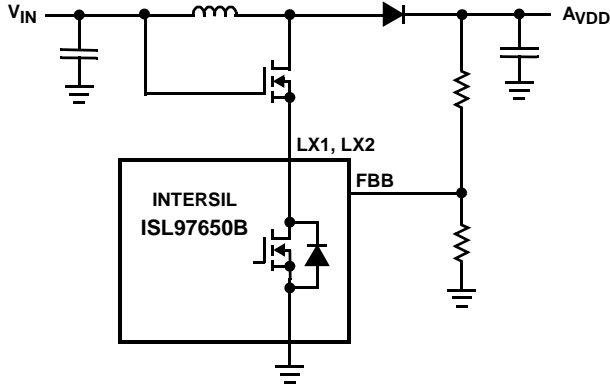

**FIGURE 15. CASCADED MOSFET TOPOLOGY FOR HIGH OUTPUT VOLTAGE APPLICATIONS**

**Buck Converter**

The buck converter is the step-down converter, which supplies the current to the logic circuit of the LCD system. The ISL97650B integrates an 20V N-Channel MOSFET to save cost and reduce external component count. In the continuous current mode, the relationship between input voltage and output voltage is in Equation 10:

$$\frac{V_{LOGIC}}{V_{IN}} = D \tag{EQ. 10}$$

Where D is the duty cycle of the switching MOSFET. Because D is always less than 1, the output voltage of buck converter is lower than the input voltage.

The peak current limit of buck converter is set to 2A, which restricts the maximum output current (average) based on Equation 11:

$$I_{OMAX} = 2A - \Delta I_{P-P} \tag{EQ. 11}$$

Where  $\Delta I_{P-P}$  is the ripple current in the buck inductor as shown in Equation 12,

$$\Delta I_{P-P} = \frac{V_{LOGIC}}{L \cdot f_s} \cdot (1 - D) \tag{EQ. 12}$$

Where L is the buck inductor,  $f_s$  is the switching frequency (0.5MHz).

**Feedback Resistors**

The buck converter output voltage is determined by Equation 13:

$$V_{LOGIC} = \frac{R14 + R15}{R15} \times V_{FBL} \tag{EQ. 13}$$

Where R14 and R15 are the feedback resistors of buck converter to set the output voltage. Current drawn by the resistor network should be limited to maintain the overall converter efficiency. The maximum value of the resistor network is limited by the feedback input bias current and the potential for noise being coupled into the feedback pin. A resistor network in the order of 1kΩ is recommended.

**Buck Converter Input Capacitor**

The capacitor should support the maximum AC RMS current which happens when D = 0.5 and maximum output current.

$$I_{ACRMS}(C_{IN}) = \sqrt{D \cdot (1 - D)} \cdot I_O \tag{EQ. 14}$$

Where  $I_O$  is the output current of the buck converter. Table 6 shows some recommendations for input capacitor.

**TABLE 6. INPUT CAPACITOR (BUCK) RECOMMENDATION**

CAPACITOR μF/V	SIZE	VENDOR	PART NUMBER
10/16	1206	TDK	C3216X7R1C106M
10/10	0805	Murata	GRM21BR61A106K
22/16	1210	Murata	C3225X7R1C226M

**Buck Inductor**

A 3.3μH to 10μH inductor is the good choice for the buck converter. Besides the inductance, the DC resistance and the saturation current are also the factor needed to be considered when choosing buck inductor. Low DC resistance can help maintain high efficiency, and the saturation current rating should be 2A. Table 7 shows some recommendations for buck inductor.

**TABLE 7. BUCK INDUCTOR RECOMMENDATION**

INDUCTOR	DIMENSIONS (mm)	VENDOR	PART NUMBER
4.7μH/ 2.7A <sub>PEAK</sub>	5.7x5.0x4.7	Murata	LQH55DN4R7M01K
6.8μH/ 3A <sub>PEAK</sub>	7.3x6.8x3.2	TDK	RLF7030T-6R8M2R8
10μH/ 2.4A <sub>PEAK</sub>	12.95x9.4x3.0	Coilcraft	DO3308P-103

**Rectifier Diode (Buck Converter)**

A Schottky diode is recommended due to fast recovery and low forward voltage. The reverse voltage rating should be higher than the maximum input voltage. The peak current rating is 2A, and the average current should be as shown in Equation 15:

$$I_{avg} = (1 - D) \cdot I_o \quad (\text{EQ. 15})$$

Where  $I_o$  is the output current of buck converter. Table 8 shows some diode recommended.

**TABLE 8. BUCK RECTIFIER DIODE RECOMMENDATION**

DIODE	$V_R/I_{AVG}$ RATING	PACKAGE	VENDOR
PMEG2020EJ	20V/2A	SOD323F	Philips Semiconductors
SS22	20V/2A	SMB	Fairchild Semiconductor

**Output Capacitor (Buck Converter)**

Four 10 $\mu$ F or two 22 $\mu$ F ceramic capacitors are recommended for this part. The overshoot and undershoot will be reduced with more capacitance, but the recovery time will be longer.

**TABLE 9. BUCK OUTPUT CAPACITOR RECOMMENDATION**

CAPACITOR ( $\mu$ F/V)	SIZE	VENDOR	PART NUMBER
10/6.3	0805	TDK	C2012X5R0J106M
10/6.3	0805	Murata	GRM21BR60J106K
22/6.3	1210	TDK	C3216X5R0J226M
100/6.3	1206	Murata	GRM31CR60J107M

**PI Loop Compensation (Buck Converter)**

The buck converter of ISL97650B can be compensated by a RC network connected from CM2 pin to ground.  $C_9 = 4.7\text{nF}$  and  $R_2 = 2\text{k}$  RC network is used in the demo board. The larger value resistor can lower the transient overshoot, however, at the expense of stability of the loop.

The stability can be optimized in a similar manner to that described in "PI Loop Compensation (Boost Converter)" on page 12.

**Bootstrap Capacitor (C16)**

This capacitor is used to provide the supply to the high driver circuitry for the buck MOSFET. The bootstrap supply is formed by an internal diode and capacitor combination. A 1 $\mu$ F is recommended for ISL97650B. A low value capacitor can lead to overcharging and in turn damage the part.

If the load is too light, the on-time of the low side diode may be insufficient to replenish the bootstrap capacitor voltage. In this case, if  $V_{IN} - V_{BUCK} < 1.5\text{V}$ , the internal MOSFET pull-up device may be unable to turn-on until  $V_{LOGIC}$  falls.

Hence, there is a minimum load requirement in this case. The minimum load can be adjusted by the feedback resistors to FBL.

The bootstrap capacitor can only be charged when the higher side MOSFET is off. If the load is too light which can not make the on-time of the low side diode be sufficient to replenish the bootstrap capacitor, the MOSFET can't turn on. Hence there is minimum load requirement to charge the bootstrap capacitor properly.

**Charge Pump Controllers ( $V_{ON}$  and  $V_{OFF}$ )**

The ISL97650B includes 2 independent charge pumps (see charge pump block and connection diagram, Figure 17). The negative charge pump inverts the  $V_{SUP}$  voltage and provides a regulated negative output voltage. The positive charge pump doubles or triples the  $V_{SUP}$  voltage and provided a regulated positive output voltage. The regulation of both the negative and positive charge pumps is generated by the internal comparator that senses the output voltage and compares it with the internal reference.

The pumps use pulse width modulation to adjust the pump period, depending on the load present. The pumps can provide 30mA for  $V_{OFF}$  and 20mA for  $V_{ON}$ .

**Positive Charge Pump Design Consideration**

The positive charge pump integrates all the diodes (D1, D2 and D3 shown in the "Block Diagram" on page 9) required for x2 ( $V_{SUP}$  doubler) and x3 ( $V_{SUP}$  Tripler) modes of operation. During the chip start-up sequence the mode of operation is automatically detected when the charge pump is enabled. With both C7 and C8 present, the x3 mode of operation is detected. With C7 present, C8 open and with C1+ shorted to C2+, the x2 mode of operation will be detected.

Due to the internal switches to  $V_{SUP}$  (M1, M2 and M3),  $P_{OUT}$  is independent of the voltage on  $V_{SUP}$  until the charge pump is enabled. This is important for TFT applications where the negative charge pump output voltage ( $V_{OFF}$ ) and  $A_{VDD}$  supplies need to be established before  $P_{OUT}$ .

The maximum  $P_{OUT}$  charge pump current can be estimated from Equations 16 and 17 assuming a 50% switching duty:

$$I_{MAX(2x)} \sim \min \text{ of } 50\text{mA} \text{ or } \frac{2 \cdot V_{SUP} - 2 \cdot V_{DIODE} (2 \cdot I_{MAX}) - V(V_{ON})}{(2 \cdot (2 \cdot R_{ONH} + R_{ONL}))} \cdot 0.95\text{A} \quad (\text{EQ. 16})$$

$$I_{MAX(3x)} \sim \min \text{ of } 50\text{mA} \text{ or } \frac{3 \cdot V_{SUP} - 3 \cdot V_{DIODE} (2 \cdot I_{MAX}) - V(V_{ON})}{(2 \cdot (3 \cdot R_{ONH} + 2 \cdot R_{ONL}))} \cdot 0.95\text{A} \quad (\text{EQ. 17})$$

Note:  $V_{DIODE} (2 \cdot I_{MAX})$  is the on-chip diode voltage as a function of  $I_{MAX}$  and  $V_{DIODE} (40\text{mA}) < 0.7\text{V}$ .

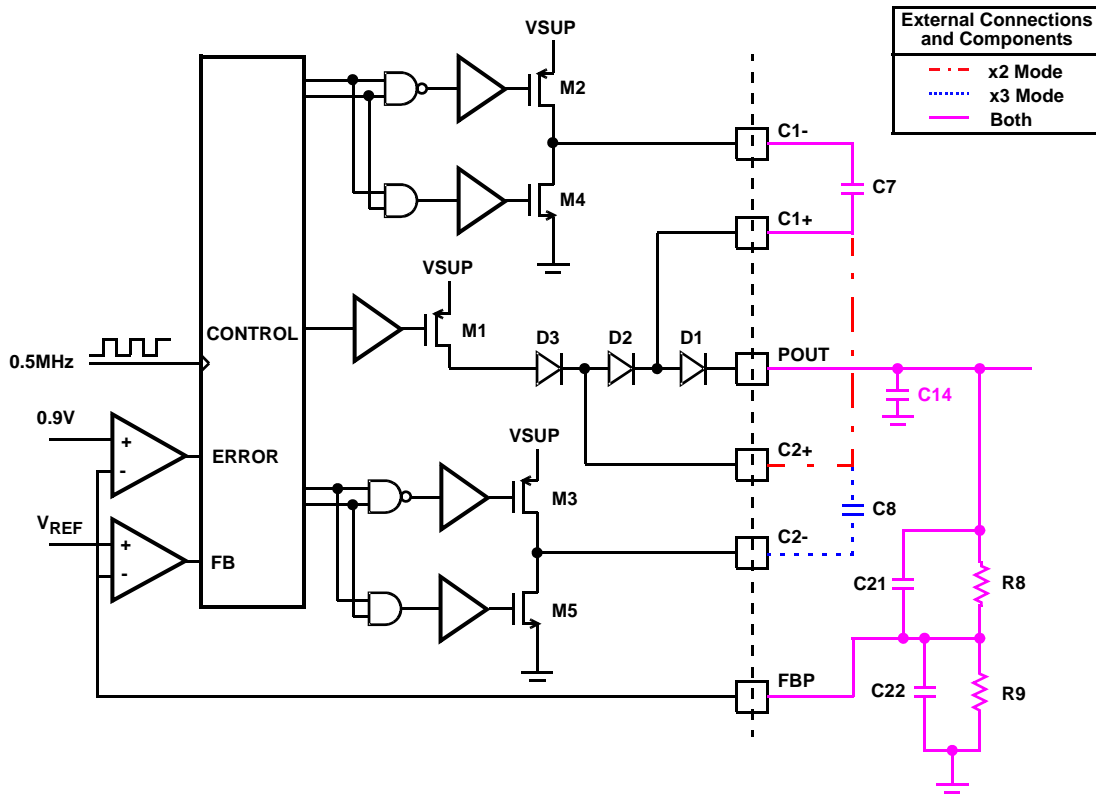

FIGURE 16.  $V_{ON}$  FUNCTION DIAGRAM

In voltage doubler configuration, the maximum  $V_{ON}$  is as given by Equations 18, 19 and 20:

$$V_{ON\_MAX(2x)} = 2 \cdot (V_{SUP} - V_{DIODE}) - 2 \cdot I_{OUT} \cdot (2 \cdot R_{ONH} + R_{ONL}) \quad (EQ. 18)$$

For Voltage Tripler:

$$V_{ON\_MAX(3x)} = 3 \cdot (V_{SUP} - V_{DIODE}) - 2 \cdot I_{OUT} \cdot (3 \cdot R_{ONH} + 2 \cdot R_{ONL}) \quad (EQ. 19)$$

$V_{ON}$  output voltage is determined by Equation 20:

$$V_{ON} = V_{FBP} \cdot \left( 1 + \frac{R_8}{R_9} \right) \quad (EQ. 20)$$

### Negative Charge Pump Design Consideration

The negative charge pump consists of an internal switcher M1, M2 which drives external steering diodes D2 and D3 via a pump capacitor (C12) to generate the negative  $V_{OFF}$  supply. An internal comparator (A1) senses the feedback voltage on FBN and turns on M1 for a period up to half a CLK period to maintain  $V_{(FBN)}$  in regulated operation at 0.2V. External feedback resistor R6 is referenced to  $V_{REF}$ .

Faults on  $V_{OFF}$  which cause  $V_{FBN}$  to rise to more than 0.4V, are detected by comparator (A2) and cause the fault detection system to start a fault ramp on  $C_{DLY}$  pin which will cause the chip to power down if present for more than the time TFD (see "Electrical Specifications" table on page 2 and also Figure 16).



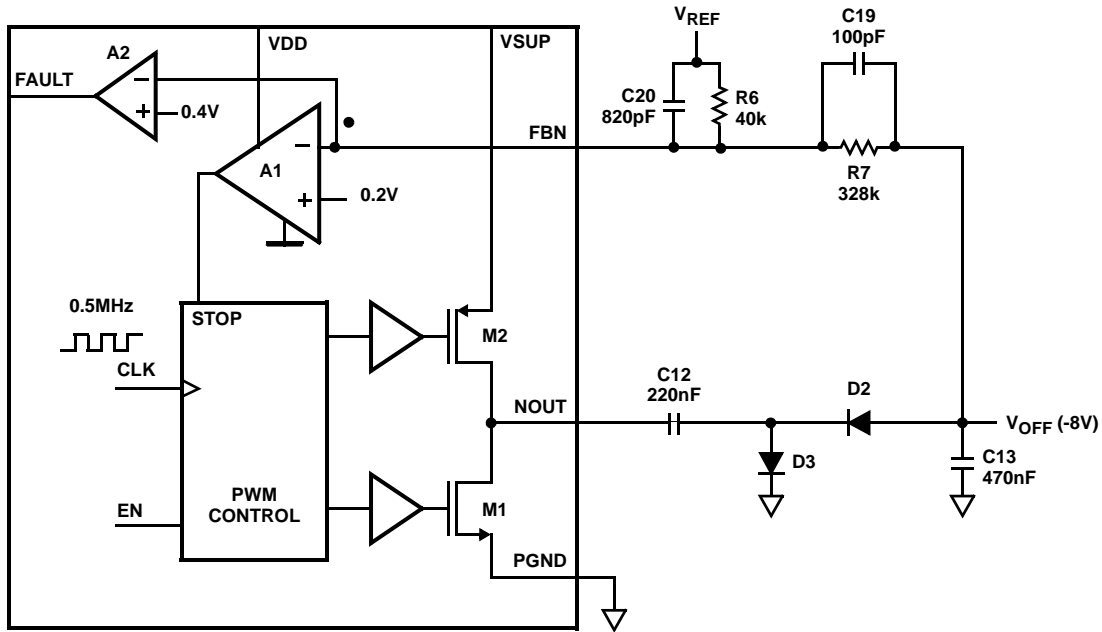

FIGURE 17. NEGATIVE CHARGE PUMP BLOCK DIAGRAM

The maximum  $V_{OFF}$  output voltage of a single stage charge pump is:

$$V_{OFF\_MAX(2x)} = -V_{SUP} + V_{DIODE} + 2 \cdot I_{OUT} \cdot (R_{ON}(NOUT)H + R_{ON}(NOUT)L) \quad (EQ. 21)$$

R6 and R7 in the “Typical Application Diagram” on page 10 determine  $V_{OFF}$  output voltage. as shown in Equation 22:

$$V_{OFF} = V_{FBN} \cdot \left(1 + \frac{R7}{R6}\right) - V_{REF} \cdot \left(\frac{R7}{R6}\right) \quad (EQ. 22)$$

**Improving Charge Pump Noise Immunity**

Depending on PCB layout and environment, noise pick-up at the FBP and FBN inputs, which may degrade load regulation performance, can be reduced by the inclusion of capacitors across the feedback resistors (e.g. in the Application Diagram, C21 and C22 for the positive charge pump). Set  $R6 \cdot C20 = R7 \cdot C19$  with  $C19 \sim 100pF$ .

**$V_{ON}$  Slice Circuit**

The  $V_{ON}$  Slice Circuit functions as a three way multiplexer, switching the voltage on COM between ground, DRN and SRC, under control of the start-up sequence and the CTL pin.

During the start-up sequence, COM is held at ground via an NDMOS FET, with  $\sim 1k$  impedance. Once the start-up sequence has completed, CTL is enabled and acts as a multiplexer control such that if CTL is low, COM connects to DRN through a  $30\Omega$  internal MOSFET, and if CTL is high, COM connects to  $P_{OUT}$  internally via a  $5\Omega$  MOSFET.

The slow rate of start-up of the switch control circuit is mainly restricted by the load capacitance at COM pin as shown in Equation 23:

$$\frac{\Delta V}{\Delta t} = \frac{V_g}{(R_i \parallel R_L) \times C_L} \quad (EQ. 23)$$

Where  $V_g$  is the supply voltage applied to DRN or voltage at  $P_{OUT}$ , which range is from 0V to 36V.  $R_i$  is the resistance between COM and DRN or  $P_{OUT}$  including the internal MOSFET  $r_{DS}(On)$ , the trace resistance and the resistor inserted,  $R_L$  is the load resistance of the switch control circuit, and  $C_L$  is the load capacitance of the switch control circuit.

In the Typical Application Circuit, R10, R11 and C15 give the bias to DRN based on Equation 24:

$$V_{DRN} = \frac{V_{ON} \cdot R11 + AVDD \cdot R10}{R10 + R11} \quad (EQ. 24)$$

And R12 can be adjusted to adjust the slew rate.



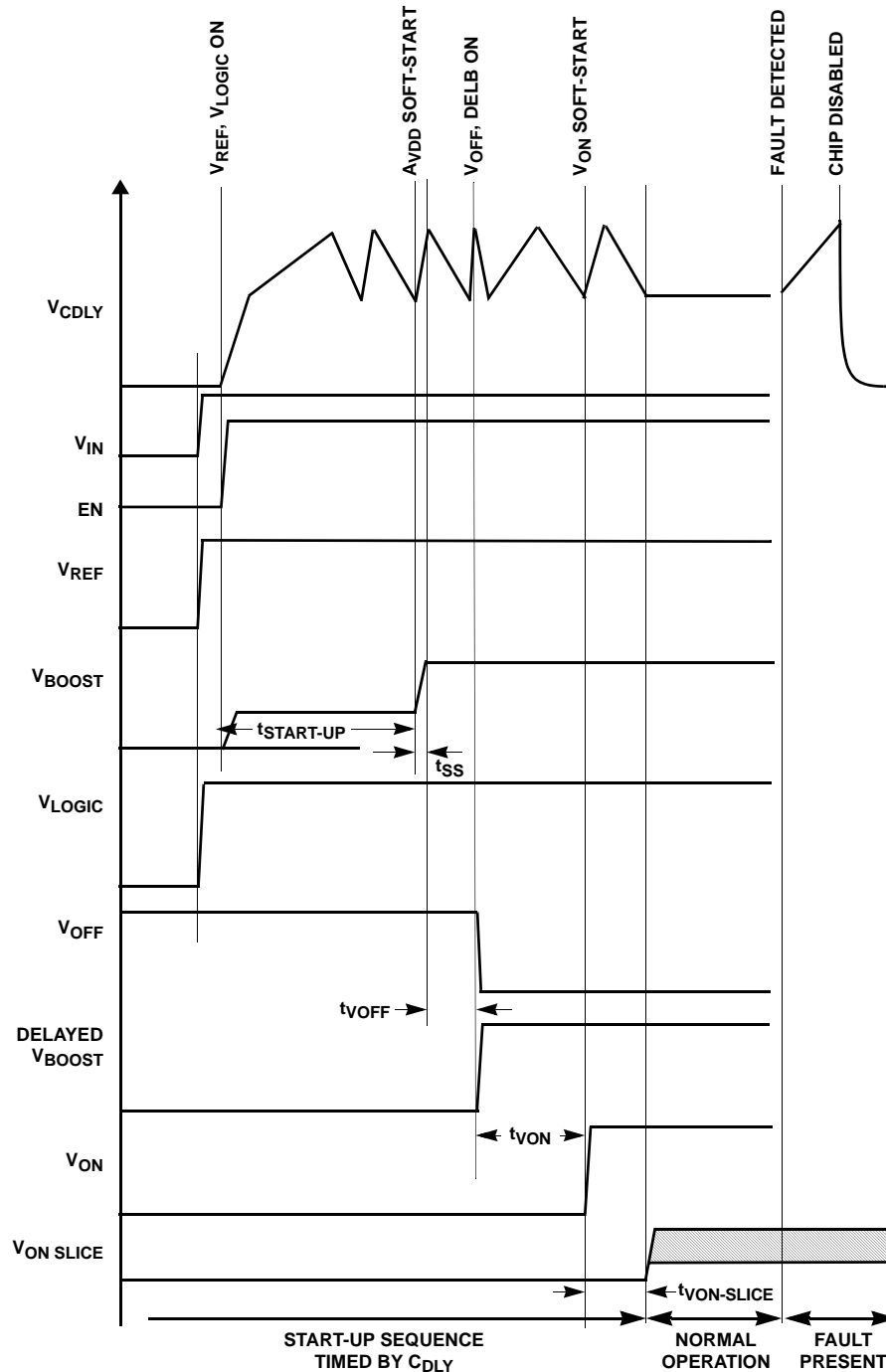

NOTE: Not to Scale

FIGURE 18. START-UP SEQUENCE

### Start-Up Sequence

Figure 18 shows a detailed start-up sequence waveform. For a successful power-up, there should be 6 peaks at  $V_{CDLY}$ . When a fault is detected, the device will latch off until either  $V_{EN}$  is toggled or the input supply is recycled.

When the input voltage is higher than 3.85V,  $V_{REF}$  turns on, as well as  $V_{LOGIC}$  if the  $V_{ENL}$  is high. an internal current source starts to charge  $C_{CDLY}$  to an upper threshold using a

fast ramp followed by a slow ramp. During the initial slow ramp, the device checks whether there is a fault condition. If no fault is found,  $C_{CDLY}$  is discharged after the first peak and  $V_{REF}$  turns on.

Initially the boost is not enabled so  $A_{VDD}$  rises to  $V_{IN} - V_{DIODE}$  through the output diode. Hence, there is a step at  $A_{VDD}$  during this part of the start-up sequence. If this step is not desirable, an external PMOS FET can be used to

delay the output until the boost is enabled internally. The delayed output appears at  $A_{VDD}$ .

$A_{VDD}$  soft-starts at the beginning of the third ramp. The soft-start ramp depends on the value of the  $C_{DLY}$  capacitor. For  $C_{DLY}$  of 220nF, the soft-start time is ~9.6ms.

$V_{OFF}$  turns on at the start of the fourth peak. At the same time, DELB gate goes low to turn on the external PMOS to generate a delayed  $A_{VDD}$  output.

$V_{ON}$  is enabled at the beginning of the sixth ramp.

Once the start-up sequence is complete, the voltage on the  $C_{DLY}$  capacitor remains at 1.15V until either a fault is detected or the EN pin is disabled. If a fault is detected, the voltage on  $C_{DLY}$  rises to 2.4V at which point the chip is disabled until the power is cycled or enable is toggled.

### ***$A_{VDD}$ \_delay Generation Using DELB***

DELB pin is an open drain internal N-FET output used to drive an external optional P-FET to provide a delayed  $A_{VDD}$  supply which also has no initial pedestal voltage (see Figure 14 on page 7), and compare the  $A_{VDD}$  and  $A_{VDD\_delayed}$  curves). When the part is enabled, the N-FET is held off until  $C_{DLY}$  reaches the 4th peak in the start-up sequence. During this period, the voltage potential of the source and gate of the external P-FET (M0 in “Typical Application Diagram” on page 10) should be almost the same due to the presence of the resistor (R4) across the source and gate, hence M0 will be off. Please note that the maximum leakage of DELB in this period is 500nA. To avoid any mis-trigger, the maximum value of R4 should be less than:

$$R_{4\_max} < \frac{V_{GS(th)\_min}(M0)}{500nA} \quad (EQ. 25)$$

Where  $V_{GS(th)\_min}(M0)$  is the minimum value of gate threshold voltage of M0.

After  $C_{DLY}$  reaches the 4th peak, the internal N-FET is turned-on and produces an initial current output of IDELB\_ON1 (~50 $\mu$ A). This current allows the user to control the turn-on inrush current into the  $A_{VDD\_delay}$  supply capacitors by a suitable choice of C4. This capacitor can provide extra delay and also filter out any noise coupled into the gate of M0, avoiding spurious turn-on, however, C4 must not be so large that it prevents DELB reaching 0.6V by the end of the start-up sequence on  $C_{DLY}$ , else a fault time-out ramp on  $C_{DLY}$  will start. A value of 22nF is typically required for C4. The 0.6V threshold is used by the chip's fault detection system and if  $V(DELB)$  is still above 0.6V at the end of the power sequencing then a fault time-out ramp will be initiated on  $C_{DLY}$ .

When the voltage at DELB falls below ~0.6V it's current is increased to IDELB\_ON2 (~1.4mA) to firmly pull the DELB voltage to ground.

If the maximum  $V_{GS}$  voltage of M0 is less than the  $A_{VDD}$  voltage being used, then a resistor may be inserted between the DELB pin and the gate of M0 such that it's potential divider action with R4 ensures the gate/source stays below  $V_{GS}(M0)_{max}$ . This additional resistor allows much larger values of C4 to be used, and hence longer  $A_{VDD}$  delay, without affecting the fault protection on DELB.

### ***Component Selection for Start-Up Sequencing and Fault Protection***

The  $C_{REF}$  capacitor is typically set at 220nF and is required to stabilize the  $V_{REF}$  output. The range of  $C_{REF}$  is from 22nF to 1 $\mu$ F and should not be more than 5x the capacitor on CDEL to ensure correct start-up operation.

The CDEL capacitor is typically 220nF and has a usable range from 47nF minimum to several microfarads - only limited by the leakage in the capacitor reaching  $\mu$ A levels.

CDEL should be at least 1/5 of the value of  $C_{REF}$  (see previous). Note, with 220nF on CDEL, the fault time-out will be typically 50ms. and the use of a larger/smaller value will vary this time proportionally (e.g. 1 $\mu$ F will give a fault time-out period of typically 230ms).

### ***Fault Sequencing***

The ISL97650B has advanced overall fault detection systems including Overcurrent Protection (OCP) for both boost and buck converters, Undervoltage Lockout Protection (UVLP) and Over-Temperature Protection.

Once the peak current flowing through the switching MOSFET of the boost and buck converters triggers the current limit threshold, the PWM comparator will disable the output, cycle-by-cycle, until the current is back to normal.

The ISL97650B detects each feedback voltage of  $A_{VDD}$ ,  $V_{ON}$ ,  $V_{OFF}$  and  $V_{LOGIC}$ . If any of the  $V_{ON}$ ,  $V_{OFF}$  or  $A_{VDD}$  feedback is lower than the fault threshold, then a timed fault ramp will appear on CDEL. If it completes, then  $V_{ON}$ ,  $V_{OFF}$  and  $A_{VDD}$  will shut down, but  $V_{LOGIC}$  will stay on.

If  $V_{LOGIC}$  feedback is lower than the fault threshold, then all channels will switch off, and  $V_{IN}$  or Enable needs recycling to turn them on again.

An internal temperature sensor continuously monitors the die temperature. In the event that the die temperature exceeds the thermal trip point of +150°C, the device will shut down. Operation with die temperatures between +125°C and +150°C can be tolerated for short periods of time, however, in order to maximize the operating life of the IC, it is recommended that the effective continuous operating junction temperature of the die should not exceed +125°C.

## Layout Recommendation

The device's performance including efficiency, output noise, transient response and control loop stability is dramatically affected by the PCB layout. PCB layout is critical, especially at high switching frequency.

There are some general guidelines for layout:

1. Place the external power components (the input capacitors, output capacitors, boost inductor and output diodes, etc.) in close proximity to the device. Traces to these components should be kept as short and wide as possible to minimize parasitic inductance and resistance.
2. Place  $V_{REF}$  and  $V_{DC}$  bypass capacitors close to the pins.
3. Reduce the loop with large AC amplitudes and fast slew rate.
4. The feedback network should sense the output voltage directly from the point of load, and be as far away from LX node as possible.
5. The power ground (PGND) and signal ground (SGND) pins should be connected at only one point.
6. The exposed die plate, on the underneath of the package, should be soldered to an equivalent area of metal on the PCB. This contact area should have multiple via connections to the back of the PCB as well as connections to intermediate PCB layers, if available, to maximize thermal dissipation away from the IC.
7. To minimize the thermal resistance of the package when soldered to a multi-layer PCB, the amount of copper track and ground plane area connected to the exposed die plate should be maximized and spread out as far as possible from the IC. The bottom and top PCB areas especially should be maximized to allow thermal dissipation to the surrounding air.
8. Minimize feedback input track lengths to avoid switching noise pick-up.

A demo board is available to illustrate the proper layout implementation.

All Intersil U.S. products are manufactured, assembled and tested utilizing ISO9000 quality systems. Intersil Corporation's quality certifications can be viewed at [www.intersil.com/design/quality](http://www.intersil.com/design/quality)

*Intersil products are sold by description only. Intersil Corporation reserves the right to make changes in circuit design, software and/or specifications at any time without notice. Accordingly, the reader is cautioned to verify that data sheets are current before placing orders. Information furnished by Intersil is believed to be accurate and reliable. However, no responsibility is assumed by Intersil or its subsidiaries for its use; nor for any infringements of patents or other rights of third parties which may result from its use. No license is granted by implication or otherwise under any patent or patent rights of Intersil or its subsidiaries.*

For information regarding Intersil Corporation and its products, see [www.intersil.com](http://www.intersil.com)

# Package Outline Drawing

## L36.6x6

36 LEAD THIN QUAD FLAT NO-LEAD PLASTIC PACKAGE

Rev 5, 08/08

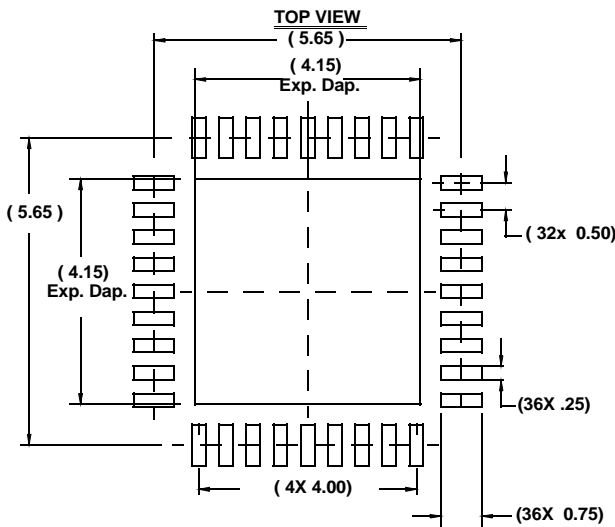
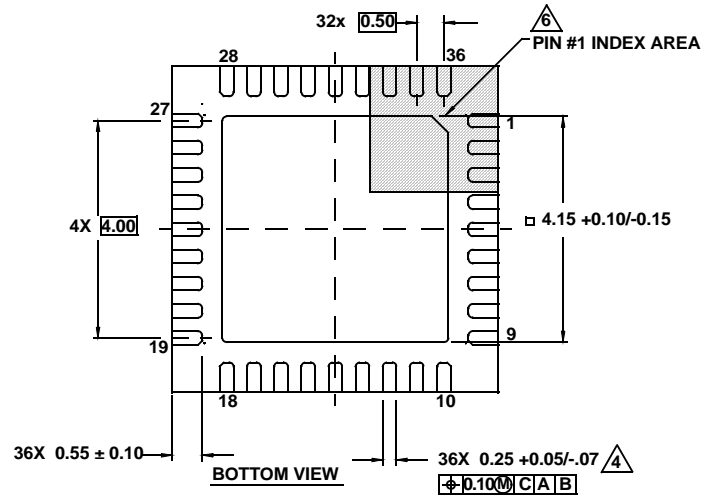
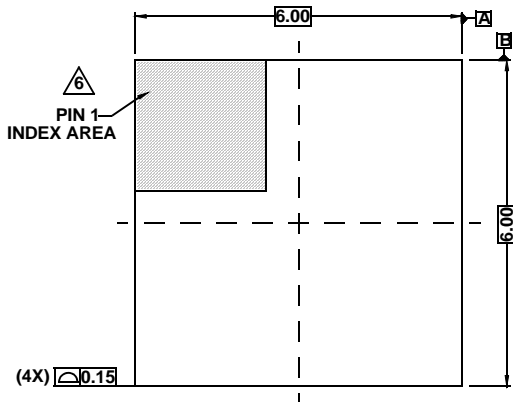

TYPICAL RECOMMENDED LAND PATTERN

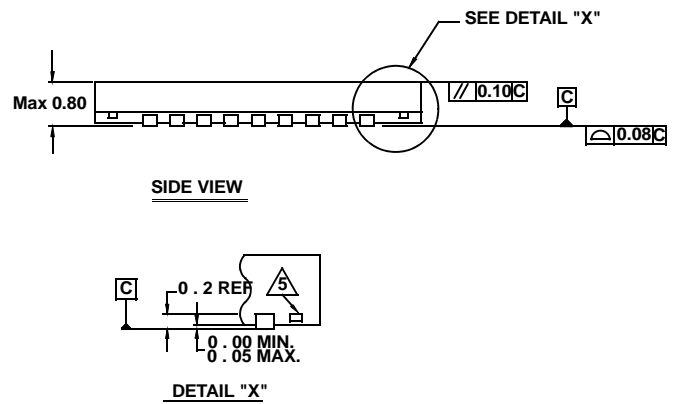

1. Dimensions are in millimeters.
2. Dimensioning and tolerancing conform to AMSEY14.5m-1994.
3. Unless otherwise specified, tolerance : Decimal  $\pm 0.05$
4. Dimension applies to the metallized terminal and is measured between 0.15mm and 0.30mm from the terminal tip.
5. Tiebar shown (if present) is a non-functional feature.
6. The configuration of the pin #1 identifier is optional, but must be located within the zone indicated. The pin #1 identifier may be either a mold or mark feature.